

THE INFORMATION CONTAINED IN THIS DRAWING IS THE SOLE PROPERTY OF MASTERPIECE ARMS INC.. ANY REPRODUCTION IN PART OR WHOLE WITHOUT THE WRITTEN PERMISSION OF MASTERPIECE ARMS INC. IS PROHIBITED.

ITEM	PART NO.	DESCRIPTION	QTY.
1	MPA1-01A	45 Welded Frame Assembly	1
2	MPA1-09	45 Sear Plate	1
3	MPA1-10	45/9mm Sear Spring	2
4	MPA1-11	45 Trigger Bar	1
5	MPA1-12	45 Trigger	1
6	MPA1-13	45 Trigger Pin	1
7	MPA1-14	45 Semi Wire Retainer	1
8	MPA1-15	45 Safety Selector	1
9	MPA1-16M	45 Hammer	1
10	MPA1-17	L.H. Hammer Spring	1
11	MPA1-18	R.H. Hammer Spring	1
12	MPA1-19-1	45 Hammer Spacer	1
13	MPA1-19M	Hammer Pin	1
14	MPA930-20	Hammer Pin Retainer	1
15	MPA1-21	45/9mm Back Grip	1
16	MPA1-22	45/9mm Back Grip Screw	1
17	MPA1-23	45 Mag. Catch	1
18	MPA1-24	45/9mm Mag. Catch Pin	1
19	MPA1-25	45/9mm Mag. Catch Spring	1
20	MPA1-66	Trigger Boot	1
21	MPA1-67	45 Sear Spring Holder	1

Assembly Instructions:

1. Install sear plate (item 2) in frame and slide towards front of gun.
2. Install sear springs (item 3) onto back posts of sear plate (item 2).
3. Insert sear spring holder (item 21) into frame as shown and slide sear plate towards rear of gun. The back of the sear spring holder must be against the back wall of the frame. Note: The wide part of the Sear Spring Holder must be at the top.
4. Install the trigger bar (item 4), oriented as shown, so that the front legs of the sear plate overlap the back of the trigger bar.
5. Install the semi wire retainer (item 7) so that the front leg goes under the frame reinforcement bar and the upside-down "V" shape at the back fits into the notch on the right side to the trigger guard.
6. Insert the trigger (item 5) as shown into the corresponding slot of the frame. Doing this will push the trigger bar and sear plate back compressing the sear spring.
7. Insert the trigger pin (item 6), through corresponding hole in the right side of the frame and then through the trigger (item 5). Push the semi wire retainer down until the trigger pin will go over it and into the opposing hole in the frame. The semi wire retainer should snap into the groove of the trigger pin.
8. To install the safety selector (item 8), use a flat blade screwdriver to pry up on the semi wire retainer until the safety selector can be inserted into the hole in the frame and under the semi wire retainer. The safety selector should go all the way in until the shoulder touches the frame. Make sure the semi wire retainer fits into the groove of the safety selector next to the inside of the frame. Tip: Wrap the shaft of your screwdriver with electrical tape to keep from scratching your frame when prying up on the semi wire retainer.
9. Install the left and right hammer springs (items 10 & 11) on the hammer (item 9). This is accomplished by sliding the coiled area of the spring over the posts of the hammer then using a flat blade screwdriver, press the "hook" on the spring through the slot on the hammer. Complete this for both sides.
10. Install the hammer by inserting the tails of the hammer springs into the cavity under the sear plate. Align the hole in the hammer with the corresponding holes in the frame.
11. Insert the hammer pin (item 13) through the hole in the frame and hammer until the end of the pin is flush with the hammer. Place the hammer spacer (item 12) between the frame and hammer and then finish pushing the pin through.
12. Slide the hammer pin retainer (item 14) over the groove on the hammer pin. Using a soft object that will not scratch the side of the frame (a credit card or drivers license works well) push the retainer on to the hammer pin until it "clicks" into place.
13. At this point, the hammer should be over the magazine well. Cock the hammer. This is done by rotating the hammer up, back (toward the back of the frame) and down until it "clicks" and locks into place on the sear plate. Note: The hammer has to be in the cocked position to install the upper receiver.
14. Insert the trigger boot (item 20) onto the trigger. Proceed to install the upper receiver and bolt assembly onto the gun.

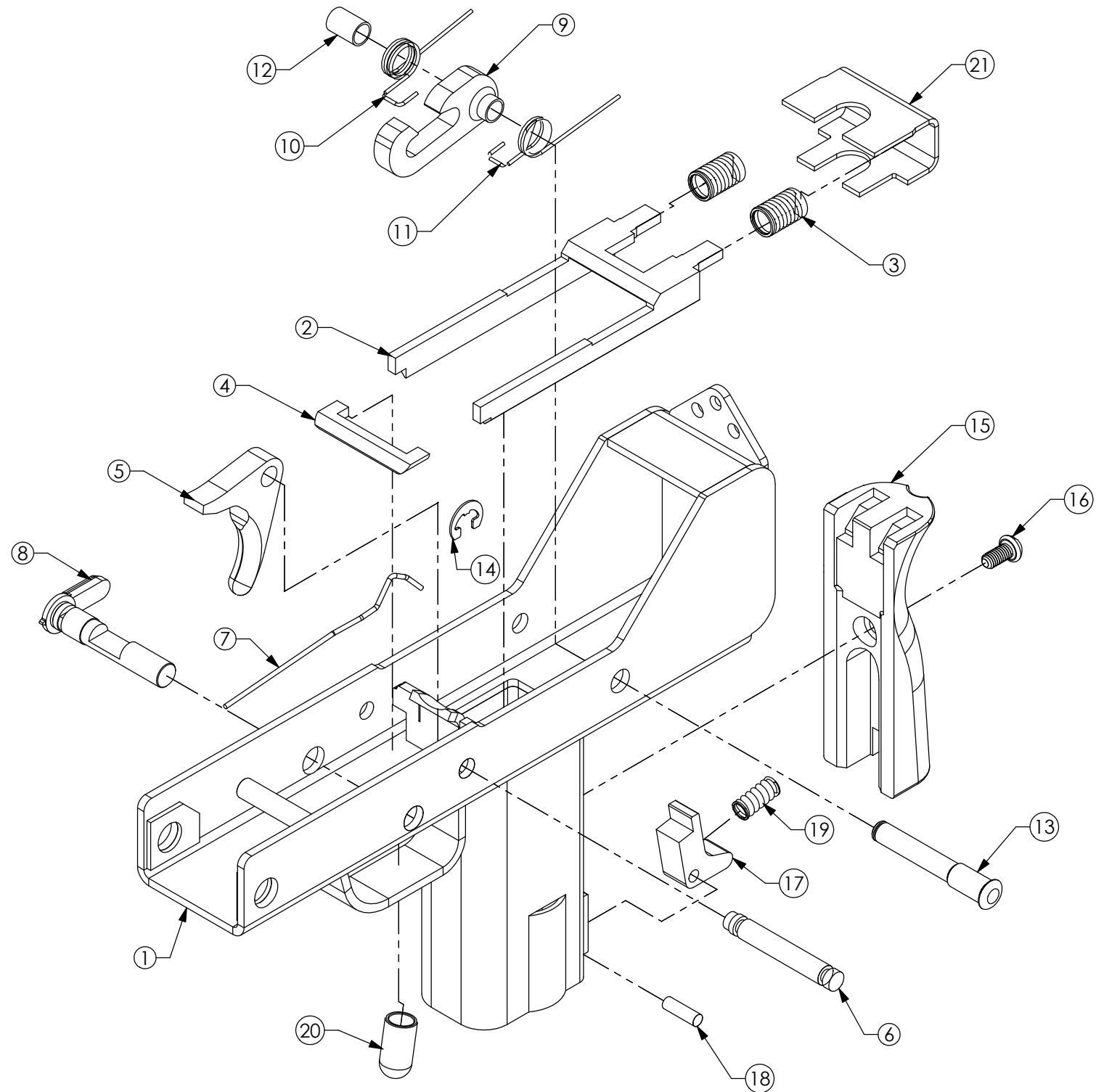

UNLESS OTHERWISE SPECIFIED DIMENSIONS ARE IN INCHES. TOLERANCES ARE:	Fractions ± 1/32 xx ± .015 xxx ± .005 angle ± 1/2°	Master Piece Arms MPA1A01B .45 ACP Lower Assembly
Drawn By: DS	Date: 3/12/2008	
Material:		
Heat Treat:		
Finish:		
DO NOT SCALE DRAWING		Scale 1:1.6
		Filename: MPA1A01B